

ASSEMBLY INSTRUCTIONS

N<sup>o</sup>RTH<sup>®</sup>  
BEDS  
SCANDINAVIAN SLEEPING

NORDIC DESIGN AND COMFORT



## Sleep well in a bed from North Beds

All of our beds come with a 25-year warranty against broken bed frames and box springs, as well as a 5-year total satisfaction guarantee. The North Beds collection is also certified in accordance with the Oeko-tex® Standard 100 and Certipur, which guarantees that our products contain no form of allergenic or harmful chemicals.

The North Beds Customer Satisfaction Guarantee gives you 90 days to exchange your mattress in case you selected the wrong firmness for your bed. This guarantee covers models that have firmness options.



# Maintenance

## Let the bed mold to your body shape

Our beds are made of soft materials that provide a good level of comfort for sleeping. After some use, you will be able to notice how the bed molds to your body shape and the way you sleep. This is to be expected with regular use. Neither the functionality nor the strength of the bed are affected by the bed's adjustment to you and your body.

## Maintenance

- Rotate your bed (bed frame and mattress) 180 degrees once or twice a year to maintain the bed's original level of comfort. By rotating the bed this way, the label will end up on the back of the bed every other time. Note that the mattress topper for the continental bed is also reversible.
- The bed frame legs should be tightened around two months after assembling the bed and once a year after that, as they may make noise if not maintained. Felt pads should be placed under the legs if the bed is on hard wood floors.
- Adjustable beds have many moving parts, and it is normal for the bed to make noise when adjusted. The screws need to be tightened and the joints should be lubricated regularly to minimise noise made by the components. Use a lubricant such as sewing machine oil to oil the joints.

## Info about motors

- Check that the motor is connected correctly before using the bed.
- The motor should only be hooked up to a 230 volt power supply, as indicated on the label affixed to the motor.
- Adjustable beds have electric-powered moving parts. The bed's openings and coupling systems present a danger of pinching/crushing. Playing atop the bed or misuse of the bed can cause damage to it. We therefore recommend keeping the remote control out of reach of children.
- The outside of the motor can be cleaned with mild detergents with a pH of 6-8.
- Do not disassemble the motors while the bed is in use.
- The bed must be lowered completely with the motor turned off before disassembly. This is a safety measure to prevent pinch/crush injuries or other accidents.
- The motor must always be turned off and the power supply disconnected when performing maintenance on the bed.



# Assembly

For the sake of safety when assembling the bed, at least two adults should put it together. Follow the instructions carefully. Do not use knives or other sharp objects to open the packaging, as they can damage the product inside. Note that it may take up to 72 hours after unrolling the mattress for it to lie completely flat.

## Continental bed 5859/6301/6729/6814

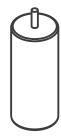

x4



x4



x2

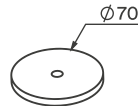

x4

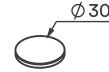

x4

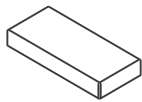

A x 2

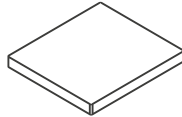

B x 1

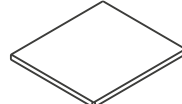

C x 1

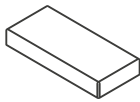

A x 2



B x 1

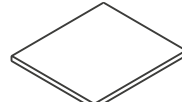

C x 1

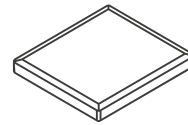

D x 1

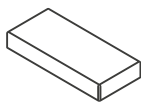

A x 2



B x 1

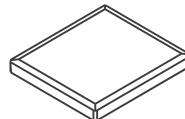

D x 1

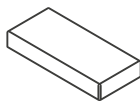

A x 2

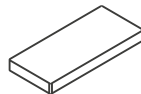

B x 2

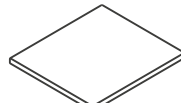

C x 1

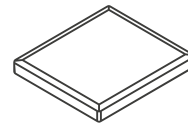

D x 1

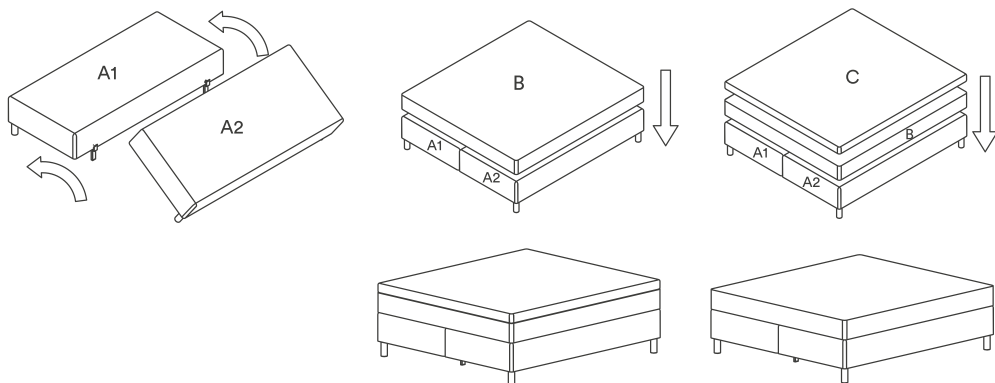
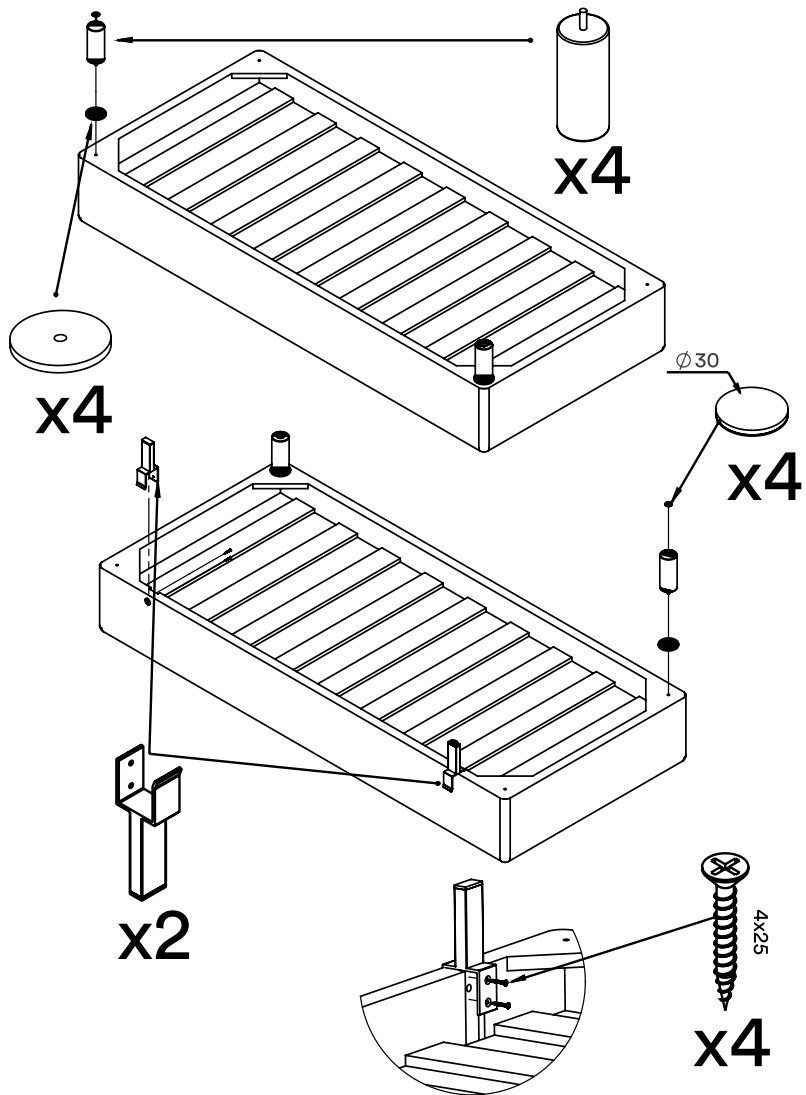





# Assembly

For the sake of safety when assembling the bed, at least two adults should put it together. Follow the instructions carefully. Do not use knives or other sharp objects to open the outside packaging, as they can damage the product inside. Note that it may take up to 72 hours after unrolling the mattress for it to lie completely flat.

## Nordic bed

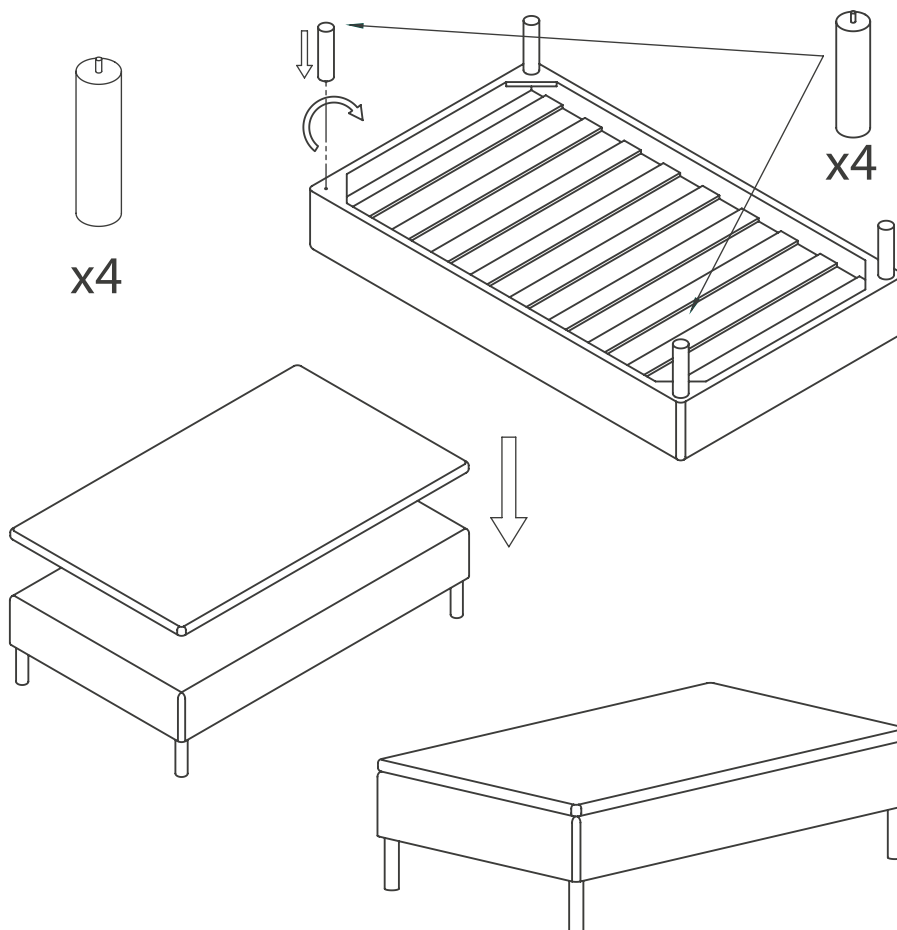

# Assembly

To properly assemble the bed, at least two adults should put it together. Follow the instructions carefully. Do not use knives or other sharp objects to open the outside packaging, as they can damage the product inside. Note that it may take up to 72 hours after unrolling the mattress for it to lie completely flat.

## Adjustable bed

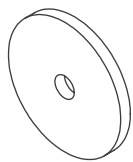

x4



x4

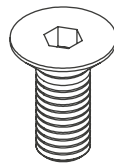

M8x16

x4



x2

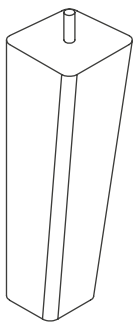

x4

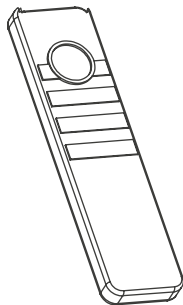

x1

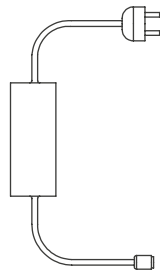

x1

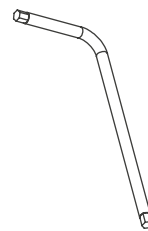

x1

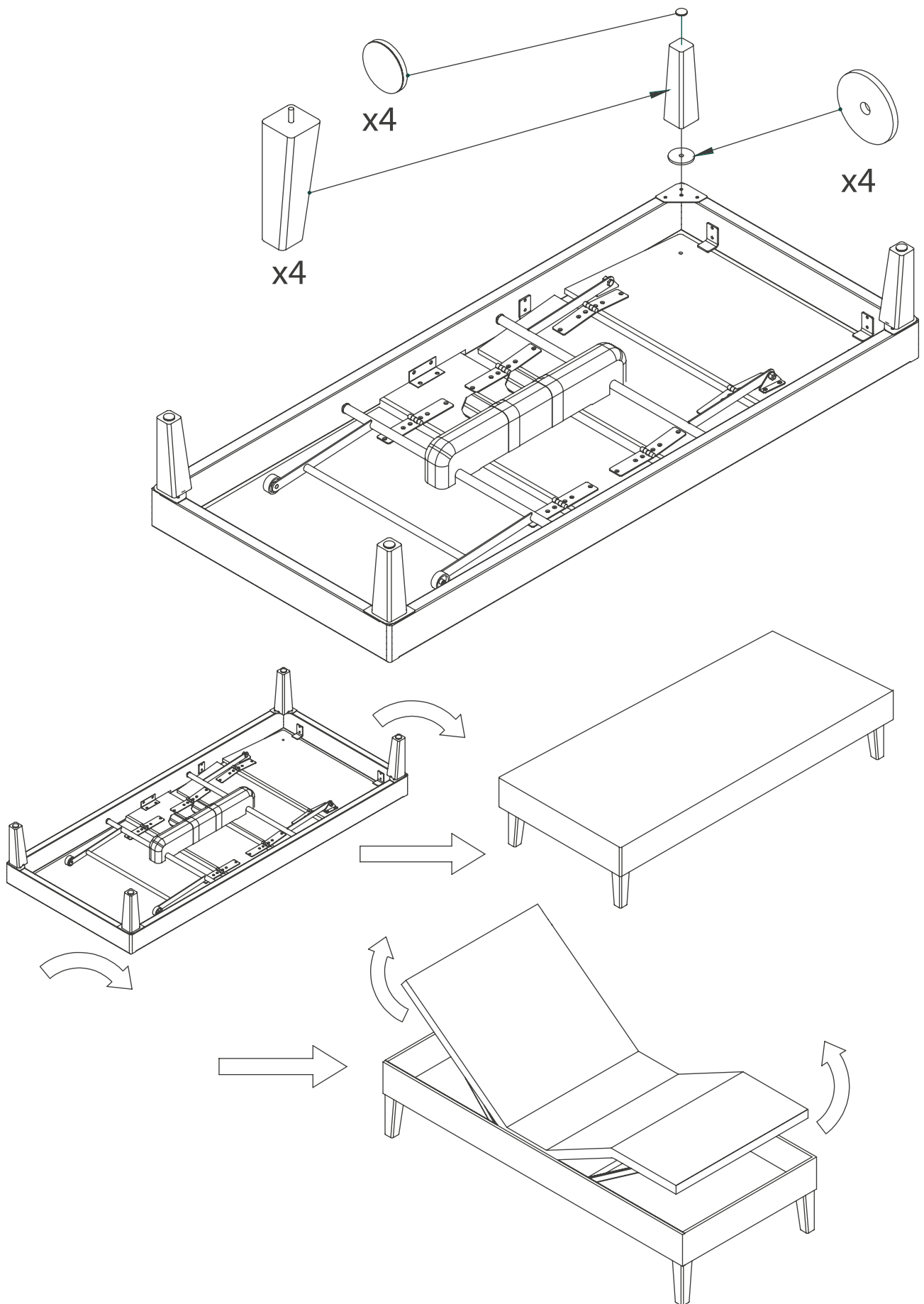

# Adjustable bed contd.

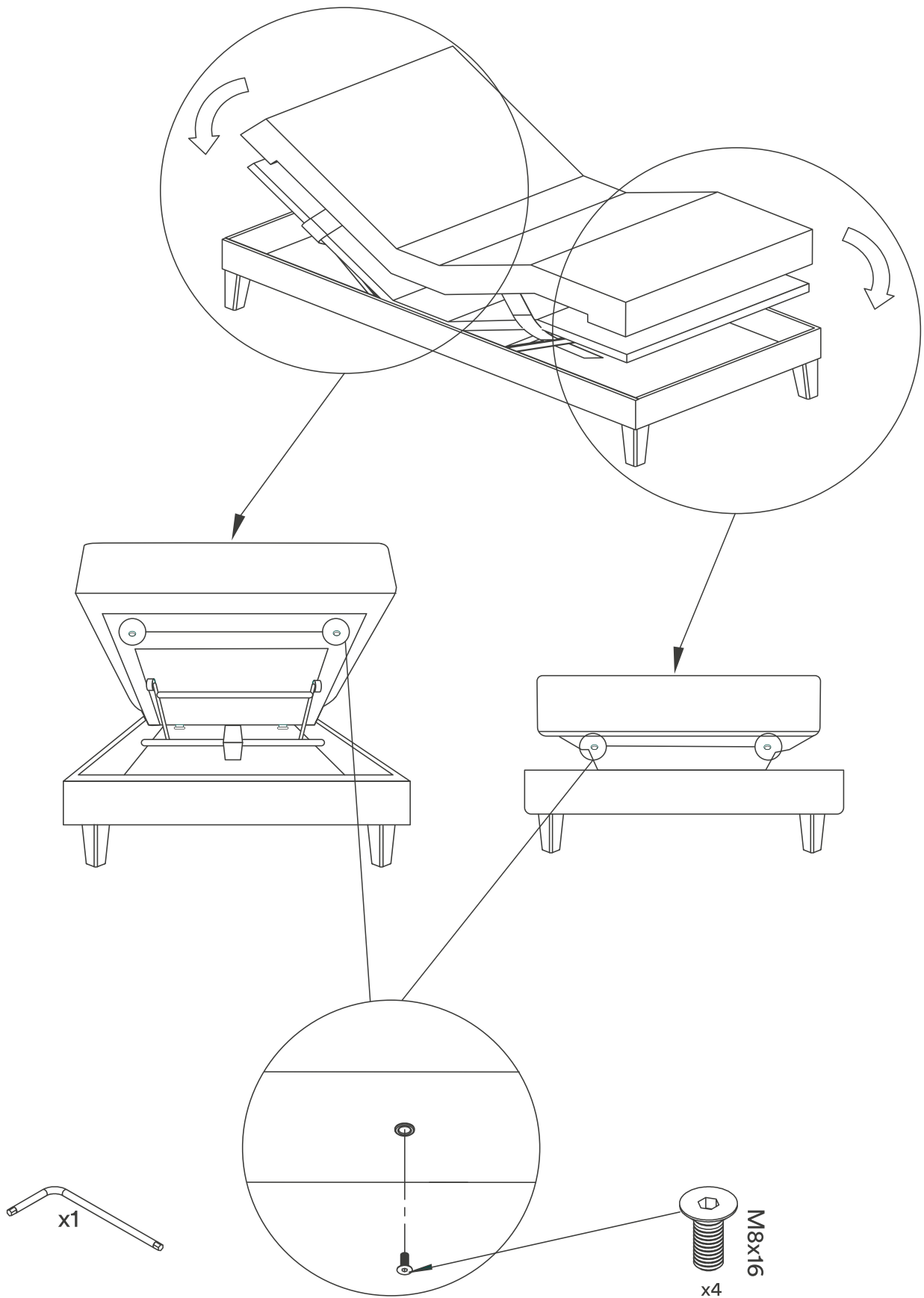

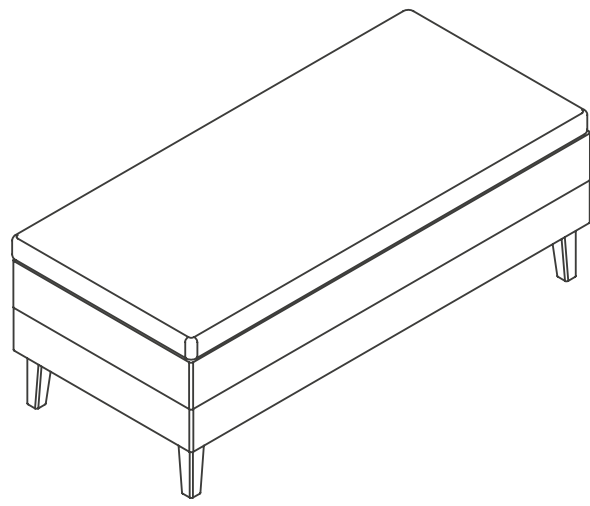
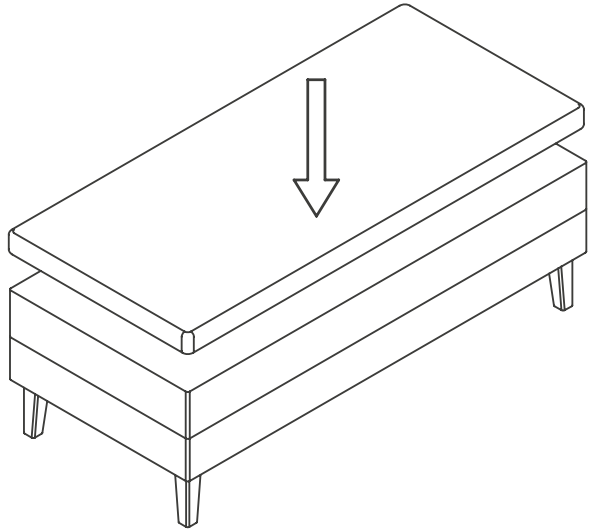
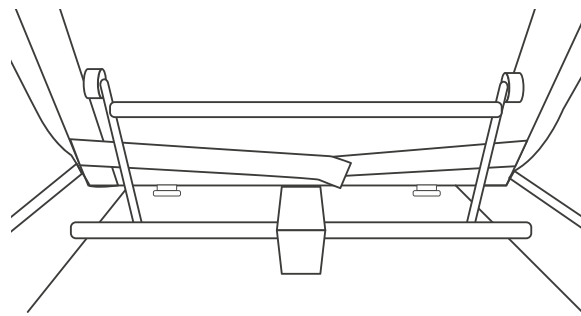
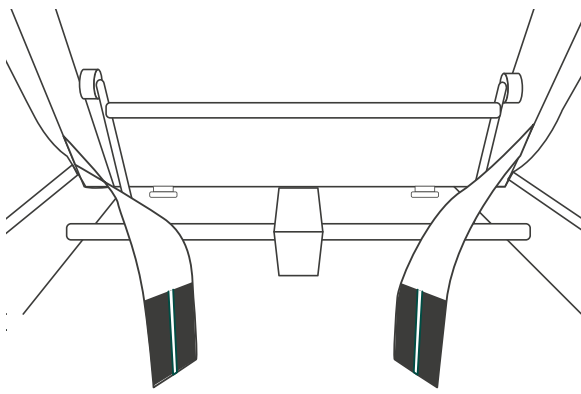
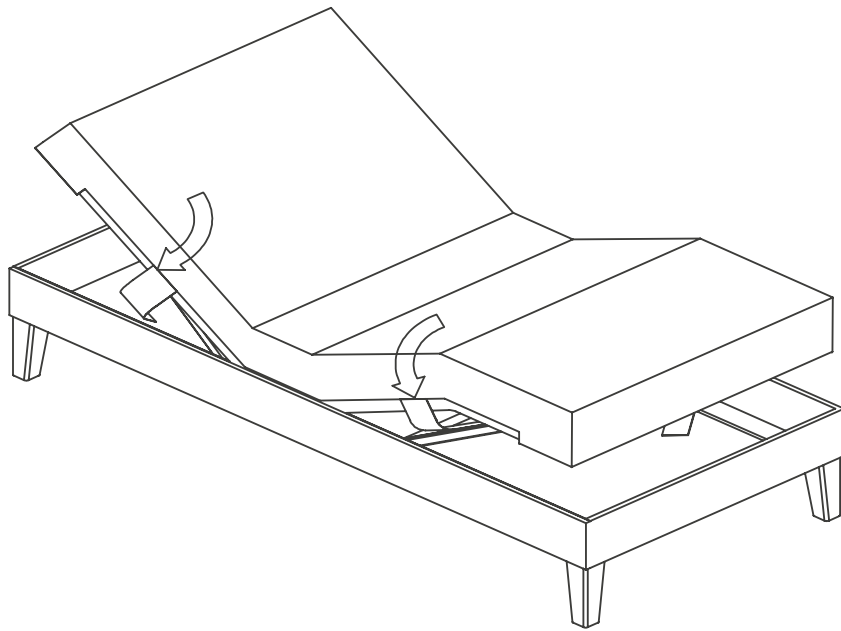

# Adjustable bed

## Start-up

- A. Put 9 volt batteries in the motor.
- B. Connect the plug to the motor and plug into a socket.

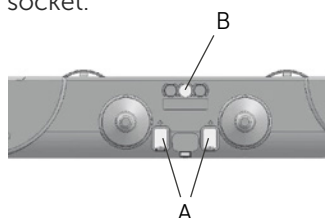

## Remote control

The battery is pre-installed and is a type CR2450. The remote control has the following functions:

1. Favourite mode
2. Turn on under bed light
3. Turn off under bed light
4. Raise head of bed
5. Lower head of bed
6. Raise foot of bed
7. Lower foot of bed
8. Raise head and foot of bed together
9. Lower head and foot of bed together



## Connect the remote control to one or both beds at the same time

1. Hold down buttons 2 and 3 simultaneously until the red light starts to blink. The remote control is now ready to connect to the bed.
2. Hold the remote control near the motor on the bed you want to connect to and press one of the "raise" or "lower" buttons until the bed starts to move.
3. Disconnect by pressing buttons 2 and 3 for just a moment, and the red light will switch off. You can now raise or lower the bed(s).
4. If you want to switch back to just raising or lowering one of the beds, simply repeat steps 1, 2 and 3.

## Save favourite position

1. Raise/lower the bed into the position you want to save.
2. Hold down the round "favourites button" until you feel the bed move slightly up and down; your favourite position has now been saved.

3. If you press the round favourites button once more, the bed will automatically lower into a horizontal position.
4. Press one more time to raise/lower the bed back into your saved favourite position.

## Under bed lighting

Briefly pressing the light button (2) will turn on the light under the bed. Increase the brightness by pressing the button again and holding it down until it reaches your desired level of brightness. Turn off the light with button number 3. The blinking red light on the remote control indicates that the batteries are low.

## Emergency lowering

If the power goes out, the bed can be lowered using the remote control. Ensure that there are 9 volt batteries in the remote. Hold down button number 5 for 5-10 seconds until the bed slowly lowers. Repeat the same process for the foot of the bed.

## Troubleshooting

If the bed stops working, check the following:

- Is it connected to a power supply? Check both the motor and the plug.
- Check whether the power supply light is lit up green.
- Check whether there are batteries in the remote control and the backlight is working.
- Disconnect from the power if necessary and wait 20 minutes.

## Use

The bed motor is not made for continuous use. The motor should not be run for more than 2 minutes within a 15-minute period. The bed is designed to support up to 150 kg. It is important to refrain from sitting at the foot of the bed when the bed is raised. Such use will void the warranty.

# Warranty

## Scope of the warranty

- Wood frames with material defects or manufacturing faults are covered by a 25-year warranty.
- Broken box springs resulting from material defects or manufacturing faults are covered by a 25-year warranty.
- Adjustable bed motors are covered by a 5-year warranty.

## What will void the warranty

- Failure to follow our instructions for use and maintenance.
- Misuse of the product. This includes incorrect or poor maintenance of the product. This also includes leaving the product in unusually dirty or unhygienic condition.
- Changing or repairing the product without permission from North Beds.
- This warranty does not grant the warranty holder any additional rights to the purchase beyond the terms and conditions of this warranty. This warranty does not, however, limit the buyer's rights in accordance with applicable, local consumer protection laws.

## Vilkår for garanti

- Present your warranty at the place you purchased your bed.
- You must be able to provide proof of purchase for the warranty to apply. This warranty, along with a valid receipt, can serve as proof of purchase.
- The warranty only applies to repairs or replacement of the product.
- If the product or parts of the product are repaired within the warranty period, the warranty period will not be extended.
- We are constantly developing our selection and product specifications can change over time. Therefore, although a product may be advertised as the same bed, the exact same bed may not be available. In such case, the advertised product is replaced with a similar product. The same applies to spare parts for bed repairs.
- Do not return your bed until you have contacted the place where you purchased it.
- The customer must pay for the cost of transporting returns to the place of purchase. The store may request compensation for costs incurred from invalid claims.



N°RTH<sup>®</sup>  
BEDS  
SCANDINAVIAN SLEEPING

N°RTH<sup>®</sup>  
BEDS

[A45] [www.northbeds.no](http://www.northbeds.no)

NORDIC DESIGN AND COMFORT

[www.northbeds.no](http://www.northbeds.no)